

OPERATION AND PARTS MANUAL

DH0602 17G24 Connect and Cut Hydraulic Chain

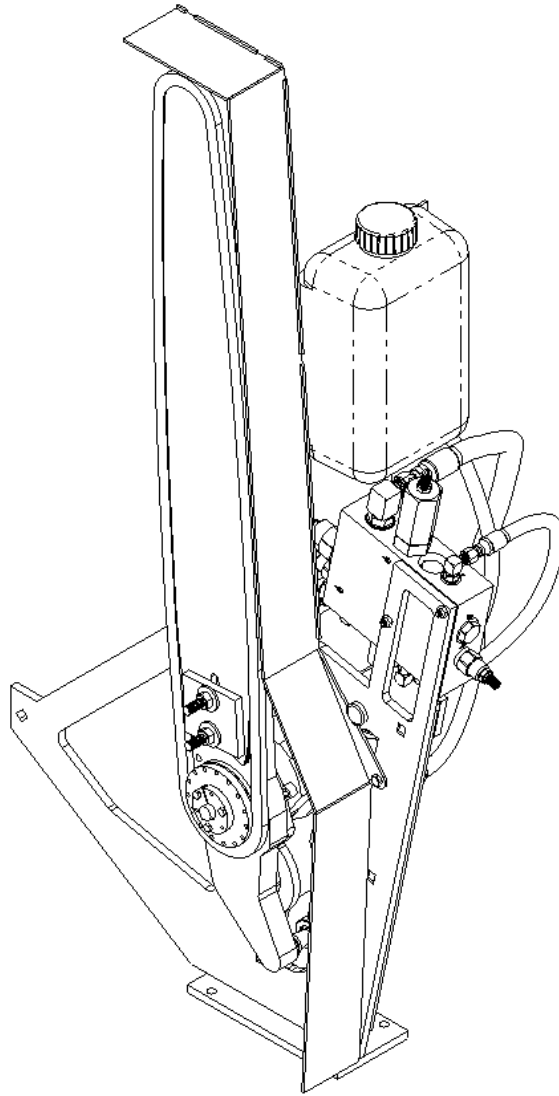

6KProducts
Bringing reliability to high pressure hydraulic systems
1006 143rd Ave S.E. Phone (360) 264-2141
Tenino, WA 98589 Fax (360) 264-5105
www.6kproducts.com

Information subject to change without notice.

SAFETY PRECAUTIONS

- ⇒ **The unit you have purchased may require you to install additional guarding to meet State and Federal safety requirements.**
- ⇒ **Do not move the log when it is being cut or when the saw is down. This action may damage the bar, chain or other components or could cause bodily harm or injury.**
- ⇒ **The log must be clamped before cutting. The bar, chain or other components could be damaged. You could suffer bodily harm or injury.**
- ⇒ **Do not make repairs or adjustments to this product other than those listed in this manual except when directed to do so by 6K Products.**
- ⇒ **All persons working near this machine must wear eye protection and hearing protection.**
- ⇒ **Use extreme caution around the cutting chain. It is sharp and may cause bodily harm or injury.**
- ⇒ **Petroleum products are used with this product. Use appropriate caution when operating or servicing. These products are flammable and may cause eye or skin irritation.**
- ⇒ **Always use 6K Products approved parts when making repairs. Replacement parts must meet or exceed the specifications of the original equipment manufacturer.**
- ⇒ **The information in this manual is subject to change without notification.**
- ⇒ **This manual is intended for safe operation and maintenance of the 6K Products, 17G24 Connect and Cut Hydraulic Chain Saw. 6K Products, welcomes any and all suggestions on how to improve this manual or the 17G24 Connect and Cut Hydraulic Chain Saw.**

Table of Contents

Cover page **1**

Safety Precaution 2

Table of Contents 3

Introduction 4

Warranty 4

Installation 4

Hydraulic Connections 5

Chain Tension and Sharpening 6

Sprocket Removal and Replacement 7

Feed Control Adjustment 8

Bar Oil Pump Adjustment 9

Operating Instruction 10

Parts and Service Information 10

Main Sub Assembly Parts 11

Bar Plate Assembly Parts 12

Feed Cylinder Assembly Parts 13

Bar Oil Pump Assembly Parts 14

Feed and Motor Control Manifold Parts 15

Bar Oil Tank Assembly Parts 16

Hose Layout 17

Introduction

Thank you for purchasing a 6K Products product. Our goal is to provide quality products for your job. This manual contains warranty information, installation information, operation instructions, parts ordering information, and service contact information.

Warranty

This 6K Products product carries a one year or 2000 hour warranty on the 6K Products designed and built components covering material and workmanship. Purchased components carry the manufactures warranty. This warranty does not cover normal wear from use, damage from abuse or misuse, damage from contamination, damage from natural disasters, fire damage or incorrect installation. This warranty does not cover labor to remove and replace parts, shipping and handling of parts, or shipping and handling for items returned for repair. If any component fails you must contact 6K Products at (360)264-2141 before doing any repair work. We will provide assistance to obtain warranty from other manufactures on their components.

Installation

When you receive the two boxes containing parts, you will need to reassemble the unit. The larger box (Fig. 2) contains the main frame sub assembly, (Fig.1, items 1 and 2). The smaller long box (Fig. 3) contains the feed cylinder (Fig. 1, item 3), feed and motor control valve (Fig. 1, item 4), bar oil tank (Fig. 1, item 5), bar guard (Fig. 1, item 6), bar oil pump (Fig. 1, item 7), saw bar (Fig. 1, item 8), saw chain (Fig. 1, item 9), weld down mount plate (Fig. 1, item 10), and assembly fasteners.

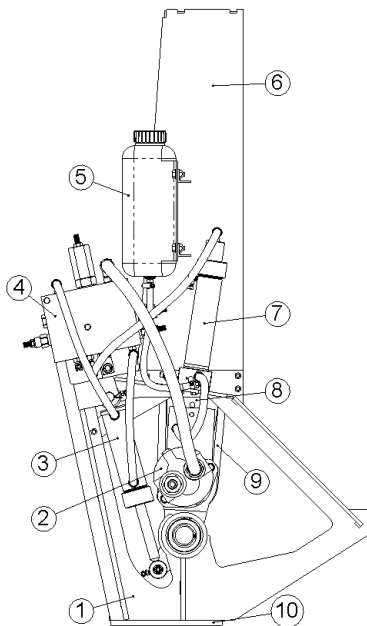

Fig. 1



Fig. 2



Fig. 3

After assembling the components as shown in figure 1, position the saw bar square to the log, at the correct height with clearance between the bar guard and the side of the largest log and weld down solidly (Fig. 4).

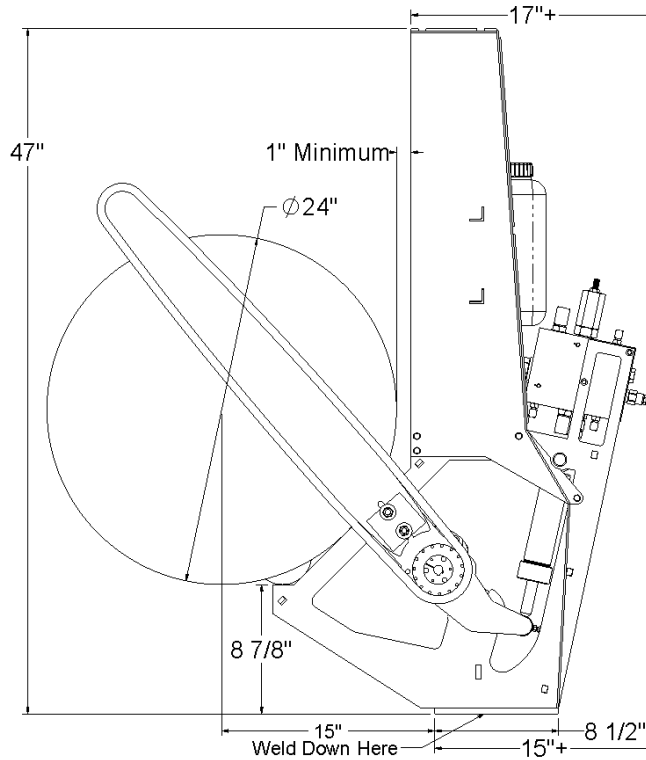

Fig. 4

Hydraulic Connections

The hydraulic requirements to operate the saw are 16 to 18 gallons per minute at 2000 psi from a directional control valve that has port A and B blocked in the neutral position. These pictures are examples of valve spool that will

work. OR The hydraulic valve can be manual or electric control. Figure 5 shows hose connections for correct operation.

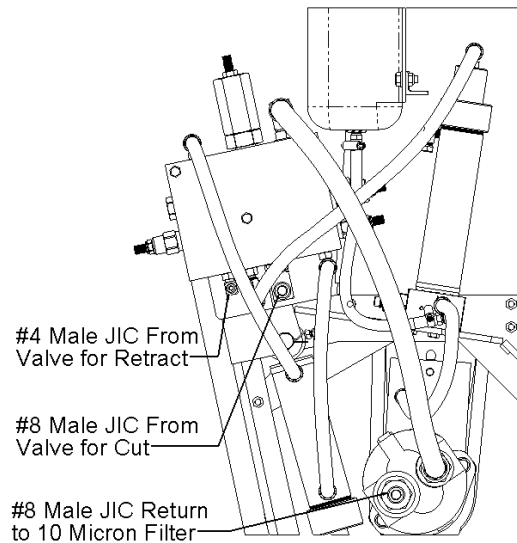

Fig. 5

The return hose can be #8 or 1/2" diameter for the first three feet, if a longer hose is required it must be #12 or 3/4" up to thirty feet. If the total return hose length is greater than thirty three feet #16 or 1" hose should be used. The filter must be rated for 20 GPM plus any additional pump flowing into it. The saw motor should run between 4000 RPM and 5500 RPM. At this speed the pressure at the return to filter connection should not exceed 80 psi when the saw motor is running. We do not recommend using quick disconnects but if you choose to use quick disconnects in the tank line, first consult the manufacture to determine the correct size to keep the back pressure low enough in cold temperatures. Failure to properly size the hose and filter or properly connect the return hose to a filter and tank will shorten the motor shaft seal life and will not be covered by warranty.

Chain Tension and Sharpening

Figure 6 shows the chain tensioning screw. A #2 or #3 Phillips screwdriver is required to turn the tension screw. With the supplied saw bar, correct tension is when the cutters come off the rails roughly 1/8" with a tug of finger pressure. Refer to the Oregon Mechanical Timber Harvesting Handbook for more tensioning information and sharpening information.

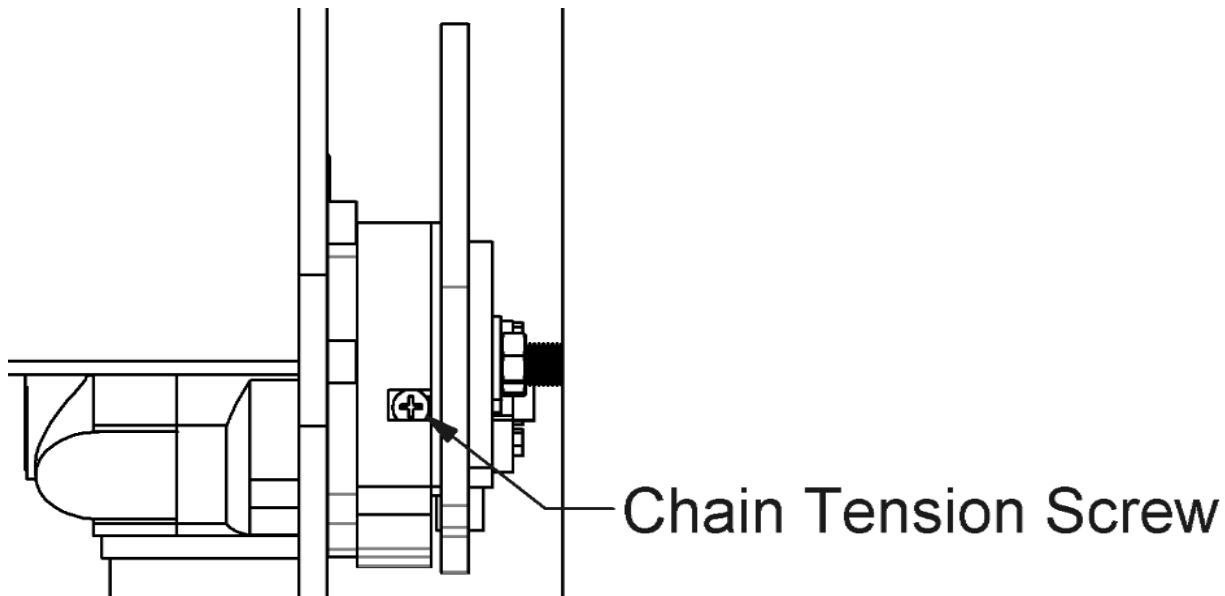

Fig. 6

Sprocket Removal and Replacement

The chain saw sprocket is connected to the shaft with a tapered bushing. To remove the sprocket remove the Cap Screws (Fig. 7, Item 3) and screw them into the Threaded Holes, tighten up to 36 inch pounds to push the Sprocket (Fig. 7, Item 1) off the bushing. You may need to tap the Sprocket towards the motor with a hammer to assist in getting the Sprocket loose from the Bushing (Fig. 7 Item 2). Lightly drive a flat blade screwdriver into the slot of the Bushing.

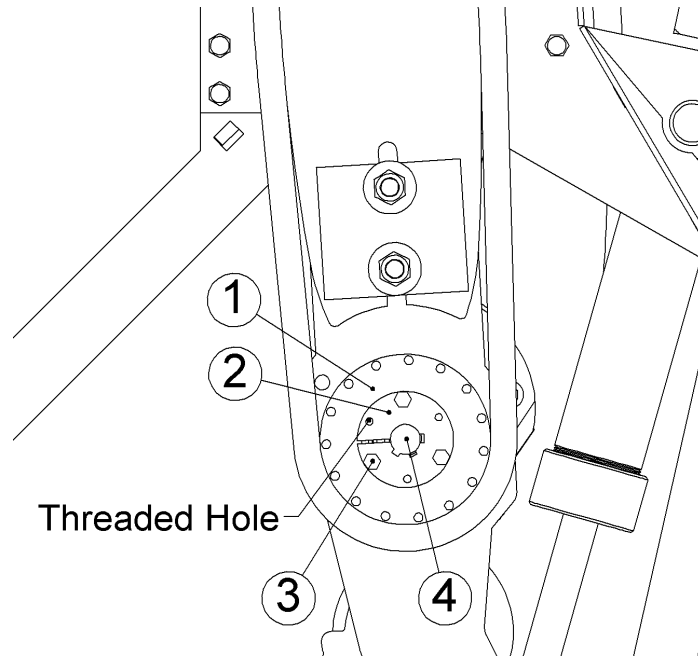

Fig. 7

Pry between the Bushing and the Sprocket to get the Bushing off the shaft. Watch that the Drive Key (Fig. 7, item 4) does not get lost.

To install the Sprocket, slide the Sprocket (Fig. 7, item 1) over the motor shaft, slide the Bushing (Fig. 7, item 2) onto the shaft with the Drive Key (Fig. 7, item 4) aligned. Position the sprocket groove offset towards the motor about the width of the bar groove with the Bushing just contacting the Sprocket. Insert the Cap Screws (Fig. 7, item 3) through the large hole in the Bushing and screw them into the threaded holes of the Sprocket. Torque the Cap Screws (Fig. 7, item 3) to 36 inch pounds. Check to make sure the sprocket groove is aligned with the bar groove. If the alignment is not correct, remove and replace the sprocket and bushing by adjusting the position before tightening the cap screws.

Feed Control Adjustments

Connect and Cut saw systems have a control manifold with cartridge valves to limit flow to the saw motor and feed cylinder, and a feed modulating valve to adjust the feed speed based on the saw motor pressure. We have tested the operation of your system to set the valves before shipping so your system should cut any diameter, species, or hardness of wood without stalling the chain in the cut. The feed modulating valve will make the bar pulsate in the cut on larger or harder wood as it is trying to cut as fast as possible. It may be possible to fine tune the cutting for your application by adjusting the saw feed speed adjustment valve (Fig. 8, item 11). For larger or harder wood loosen the jam nut with a 9/16" wrench and screw the adjustment screw out with a 5/32" hex key wrench (Allen wrench), this will slow the bar movement down, lock the jam nut down when done adjusting. For smaller softer wood you may want to speed up the bar movement by screwing the adjustment screw in. Having the bar move too fast may cause the chain to stick when starting into the cut if the chain hits a knot. It is possible to tune the feed modulating valve (Fig. 8, item 2) by loosening the jam nut with a 9/16" wrench and adjusting the screw with a 3/16" hex key. A smoother cut may be possible by screwing the adjustment screw out, but this may increase the cutting time in larger or harder wood. If the wood is dry and hard screwing the feed modulating adjustment in may decrease cutting time. Screwing the feed modulating adjustment in too far will cause the chain to stall. Be sure to lock the jam nut after adjusting a valve.

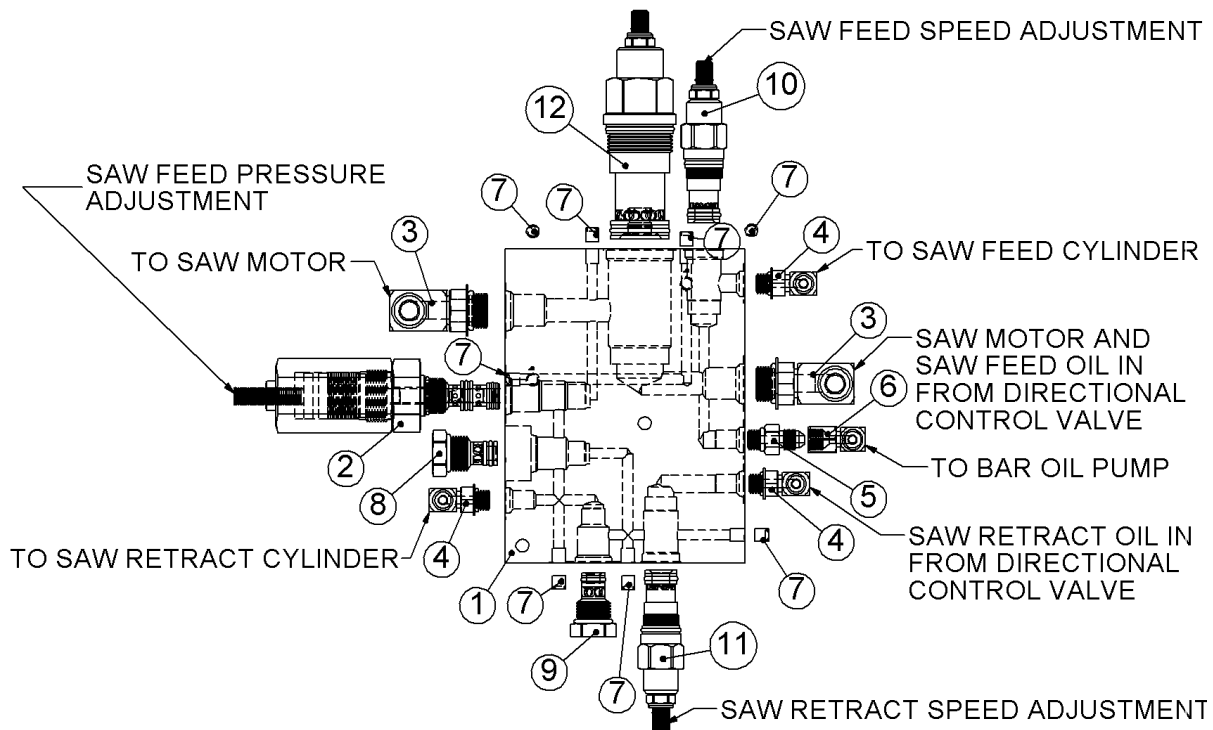

Fig. 8

Bar Oil Pump Adjustments

The DH0144 bar oil pump (Fig. 9) is a single acting pump that can pump up to 32 cc or 1.08 oz. of bar oil per cycle, enough for about 30 seconds of cutting. There is a hose connected to the feed and motor control valve manifold (Fig. 8, item 6) that connects to the fitting (Fig. 9, hydraulic pressure in) on the bar oil pump. When a cut is started flow and pressure from the manifold pushes on the pumping rod and piston to force a metered amount of oil to the bar. Very little rotational adjustment is needed for the metering valve in Figure 9. Turning it clockwise reduces the speed oil is pumped and turning it counterclockwise increases the speed the oil comes out. If you run the tank out of oil you may need to prime the pump. To prime the pump remove the barrel nut and pull the pumping chamber, pumping piston, and pumping rod. Fill the barrel with bar oil up to the vent hole. Reinstall the pumping rod assembly into the pumping chamber with care to not damage the rod seal. Reinstall the pumping rod assembly into the pumping chamber with care to not damage the rod seal. Reinstall the pumping chamber and pumping rod assembly into the barrel, with care to not damage the piston or the O-ring, and retighten the barrel nut. To reduce the chance of seal damage make sure the seals are oiled and wiggle in a circular motion as you push the parts together.

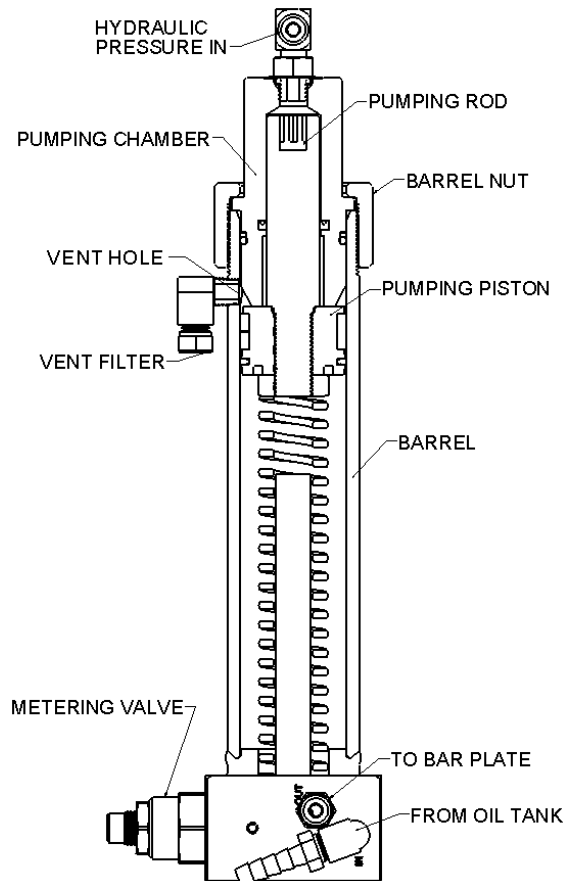

Fig. 9

Operating Instructions

Before, and periodically during, operation you must check the bar oil level and chain tension. We recommend using a good quality bar oil of the correct viscosity for your areas operating temperatures. Because of the wide temperature range between winter and summer two different viscosity oils may be required. Tension the chain as described on page 6. The log being cut must be clamped prior to sawing. Once the log is positioned and clamped the saw control valve needs to be opened for full flow to cut. After completing the cut reverse the valve and raise the saw bar. The saw motor only runs when the bar is being lowered. The bar will only receive up to 32 cc of oil when the saw motor is operating or the bar is feeding down.

Parts and Service Information

For parts and service contact 6K Products. Our hours of operation are 8:00 AM to 4:30 PM, Monday through Friday, Pacific Time excluding holidays.

Phone: 360-264-2141

Fax: 360-264-5105

Email ed@6kproducts.com

Mail and shipping address:

6K Products
1006 143rd Ave. S.E.
Tenino, WA 98589

MAIN SUB ASSEMBLIES

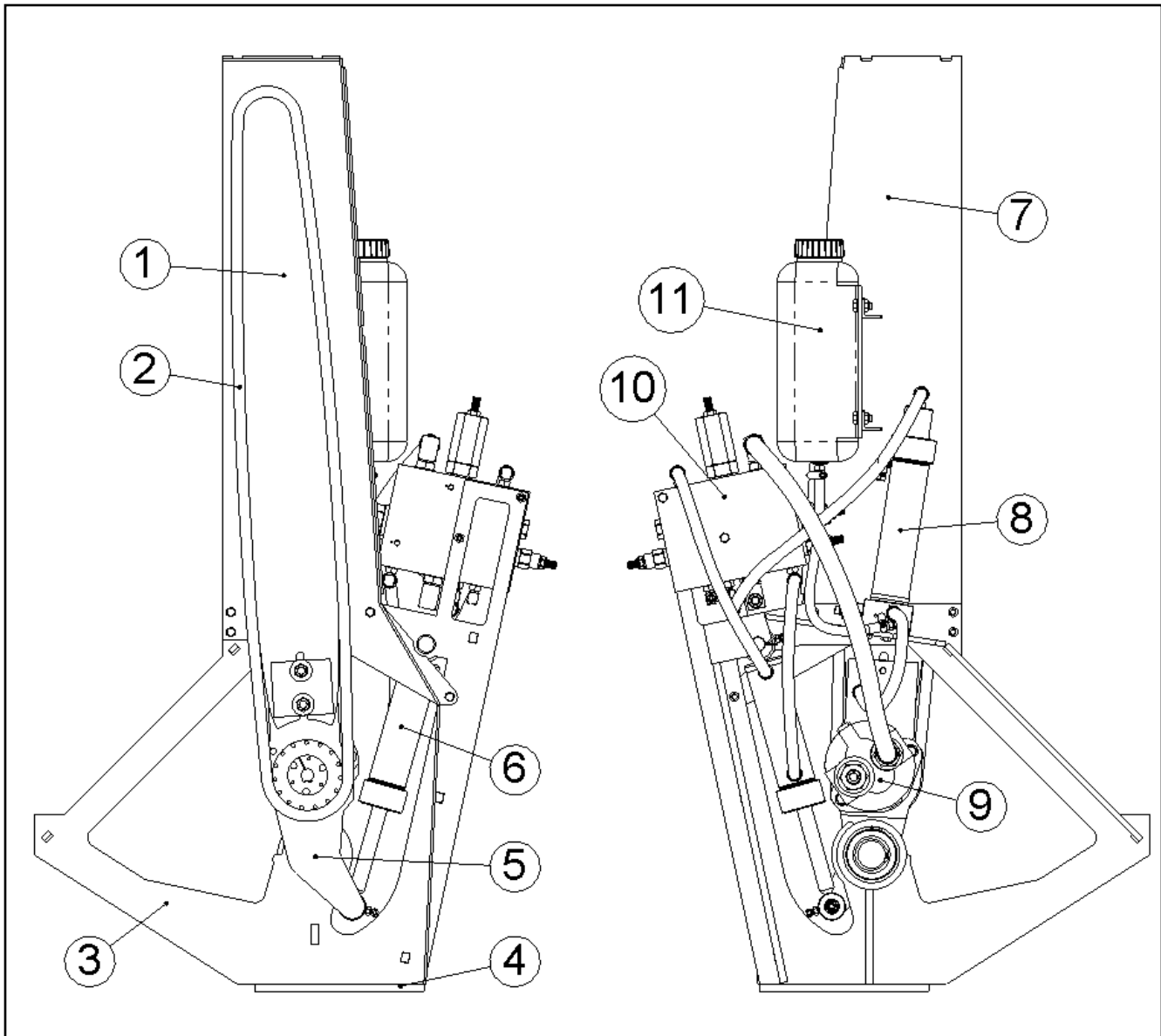

ITEM No.	QTY.	PART No.	DESCRIPTION	REMARKS
1	1	DH0066	HARVESTER BAR, 75 CM	OREGON 752HSFN114
2	1	DH0055	SAW CHAIN, 80 GAUGE, 89 DRIVE LINKS	OREGON 18HX
3	1	DH0130	MAIN FRAME	
4	1	FDTD10	DRILLED WELD DOWN PLATE	
5	1	DH0622	BAR PLATE ASSEMBLY	
6	1	DH0162	FEED CYLINDER ASSEMBLY	
7	1	DH0166	BAR GUARD WELDMENT	
8	1	DH0144	BAR OIL PUMP ASSEMBLY	
9	1	VMCR09	SAW MOTOR	
10	1	DH0191	FEED & MOTOR CONTROL MANIFOLD	
11	1	DH0152	BAR OIL TANK ASSEMBLY	

DH0621 BAR PLATE ASSEMBLY

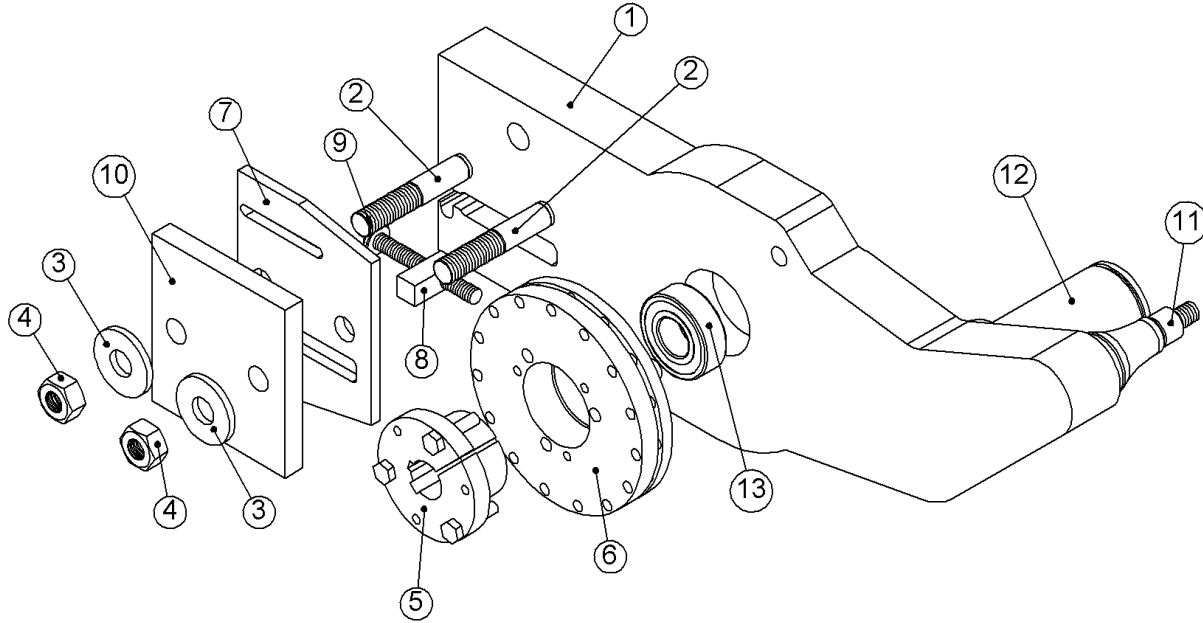

ITEM No.	QTY.	PART No.	DESCRIPTION	REMARKS
1	1	DH0622	BAR PLATE, SAE A 2 BOLT	
2	2	FST005	M10 X 1.5 X 52 STUD	
3	2	FMW100P	10MM REGULAR PLAIN WASHER	
4	2	FMN10CP	M10 X 1.5 NUT	
5	1	GM1002	QD - JA X 5/8 BUSHING	
6	1	DS0146	15T404TL SPROCKET	
7	1	DH0034	BAR SPACER	
8	1	DH0033	TENSION BAR	
9	1	FSM42P	1/4 -20 X 2 SS PAN HD PHILLIPS SCREW	
10	1	DH0122	CLAMP PLATE	
11	1	DEP001	1/2" BALL BUSHING PIN	
12	1	DH0126	PIVOT PIN	
13	1	B62RA2	BALL BEARING, 6202-2RS X 5/8" BORE	

DH0162 FEED CYLINDER ASSEMBLY

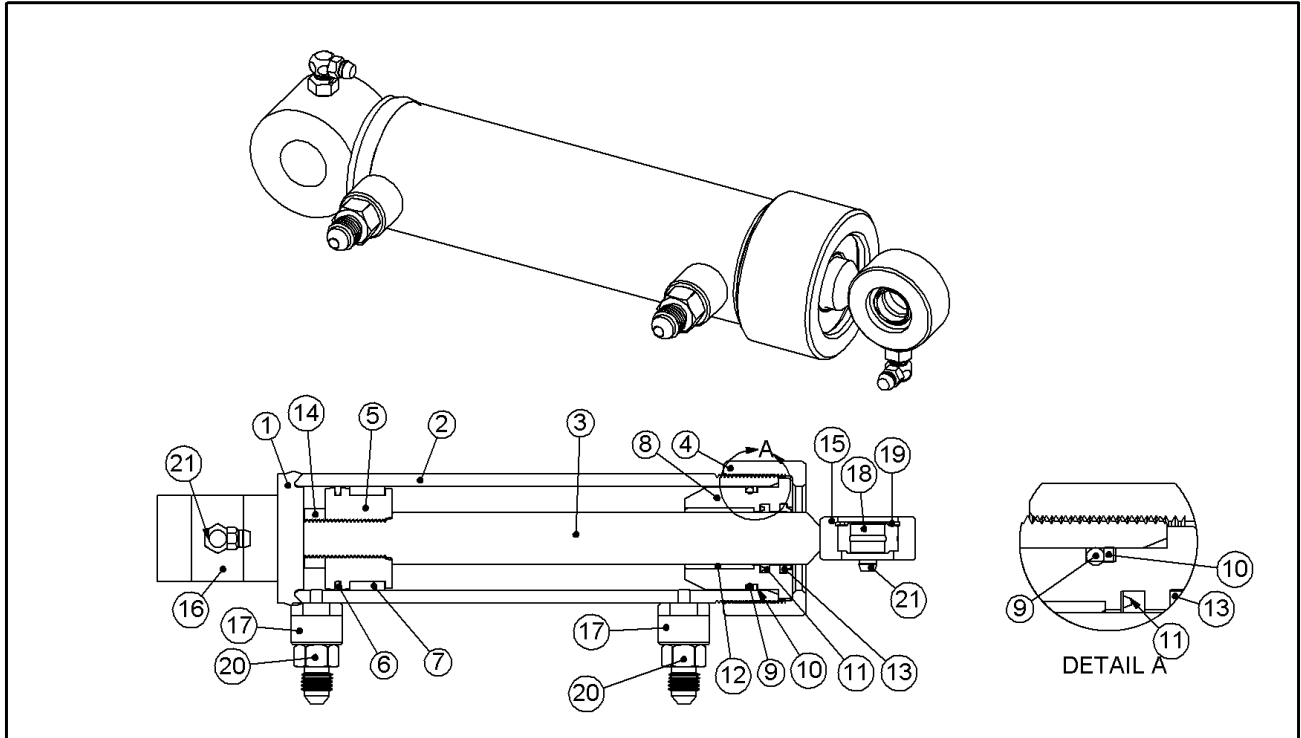

ITEM No.	QTY.	PART No.	DESCRIPTION	REMARKS
1	1	K30116	1 1/2" BORE CYL BUTT PLATE	
2	1	DH0124	1.500" BORE CYL BARREL	
3	1	DH0125	3/4" ROD	
4	1	K30121	1 1/2" BARREL NUT	
5	1	K30120	1 1/2" PISTON	
6	1	SPT026	1 1/2" TT1400 PISTON SEAL ASSY.	
7	1	SRS005	1-1/2" X 1-1/4" X 1/2" STEP CUT WEAR RING	
8	1	K30119	1 1/2" X 3/4" HEAD	
9	1	SO2125	#2-125 O-RING	
10	1	SO8125	#8-125 BACK UP RING	
11	1	SUG011	3/4 X 1 X 1/8 U-SEAL	
12	1	BP0044	BUSHING, 3/4" X 7/8" X 1", I-GLIDE G300, GSI-1214-16	
13	1	SWA005	3/4" AN-WIPER	
14	1	FNF30J	9/16" NF JAM NUT	
15	1	DES014	CYLINDER EYE	
16	1	DES068	EYE	
17	2	DPWT04	#4 O-RING THREADED WELD ON FITTING	
18	1	BBS008	1/2" BORE BALL BUSHING	
19	1	FRI087	.875 ϕ SHAFT, INTERNAL LOCK RING	
20	2	HH0657	MALE ORB TO JIC ADAPTER, 850-4-4	
21	2	FGG006	1/4-28-90, #0805-0051 GREASE FITTING	

DH0144 BAR OIL PUMP ASSEMBLY

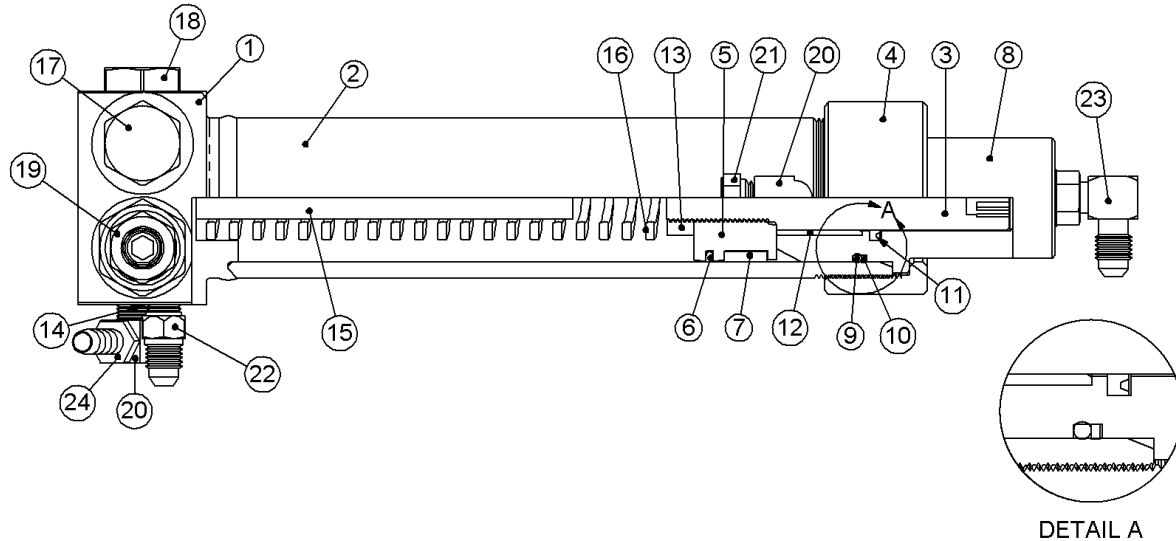

ITEM No.	QTY.	PART No.	DESCRIPTION	REMARKS
1	1	DH0147	VALVE PLATE	
2	1	DH0145	1.500" BORE CYL BARREL	
3	1	DH0146	ROD FOR DH0144	
4	1	K30121	1 1/2" BARREL NUT	
5	1	K30120	1 1/2" PISTON	
6	1	SPT026	1 1/2" TT1400 PISTON SEAL ASSY.	
7	1	SRS005	1-1/2" X 1-1/4" X 1/2" STEP CUT WEAR RING	
8	1	DH0148	PRESSURE CHAMBER	
9	1	SO2125	#2-125 O-RING	
10	1	SO8125	#8-125 BACK UP RING	
11	1	SUG011	3/4 X 1 X 1/8 U-SEAL	
12	1	BP0044	BUSHING, 3/4" X 7/8" X 1", I-GLIDE G300, GSI-1214-16	
13	1	FNF30J	9/16" NF JAM NUT	
14	1	XH0003	5/32" EXPANSION PLUG, CVES1561110A	
15	1	DH0149	SPACER	
16	1	FXC013	1 X 6 LIGHT DUTY DIE SPRING	
17	1	VHH041	CARTRIDGE VALVE, HydraForce CV08-20-0-N-25	
18	1	VHH015	CARTRIDGE VALVE, HydraForce CV08-20-0-N-04	
19	1	VHH042	CARTRIDGE VALVE, HydraForce FC10-20A	
20	2	HBP106	1/8" TO 1/8" 90° STREET ELBOW	
21	1	FGG030	1/8 NPT vent	
22	1	HH0427	MALE JIC TO PIPE ADAPTER,816-4-2	
23	1	HH0738	90° ADJUSTABLE MALE ORB TO JIC, 853-4-4	
24	1	HB0007	HOSE END, 1/8 PIPE X 1/4 HOSE	
25	1	DH0355	BAR OIL PUMP BARREL ASSEMBLY	Items 1 and 2
26	1	DH0356	SEAL KIT	Items 6,7,9,10,11 and 12

DH0191 FEED and MOTOR CONTROL MANIFOLD

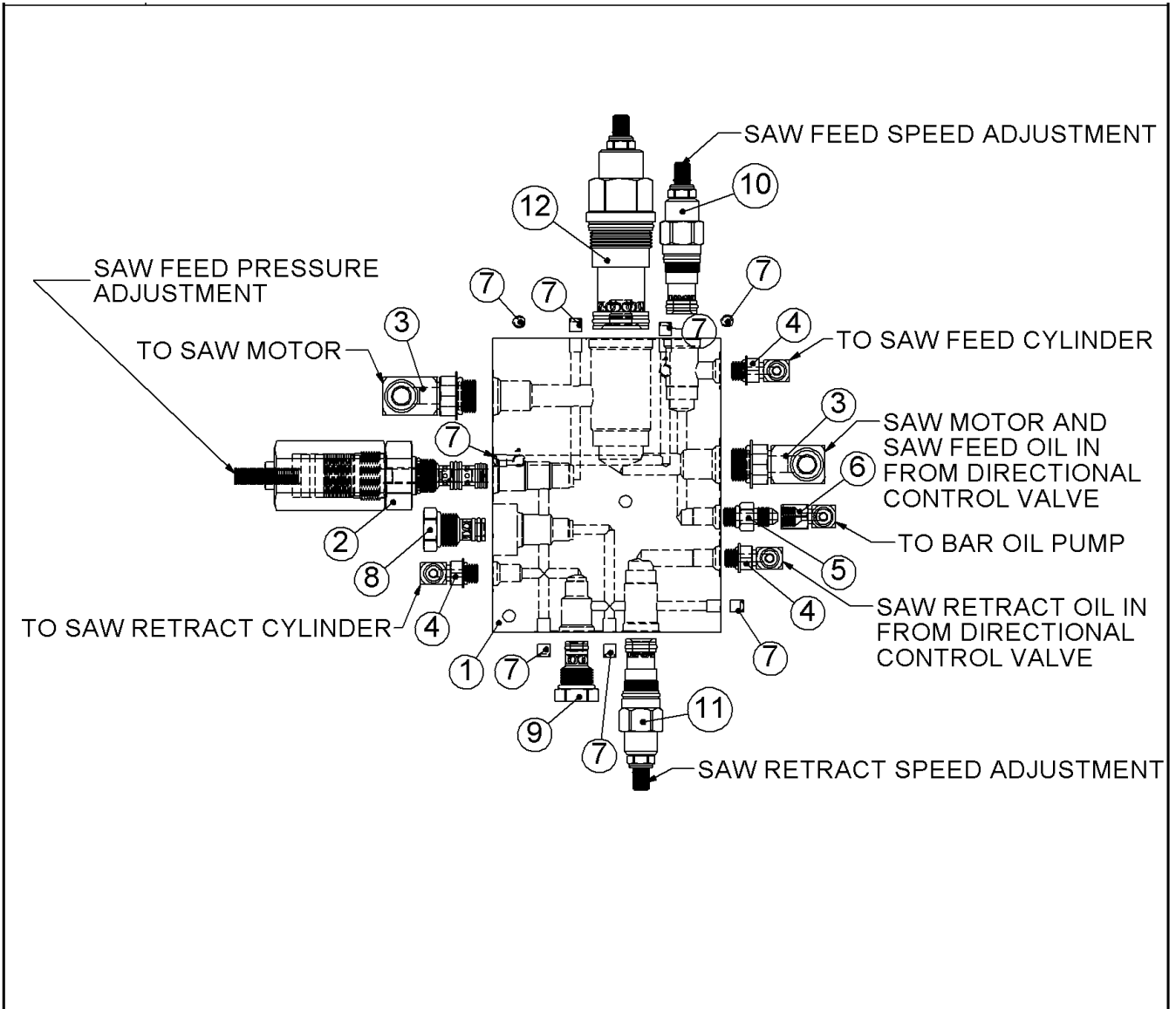

ITEM No.	QTY.	PART No.	DESCRIPTION	REMARKS
1	1	DH0194	CONTROL MANIFOLD, FXEA C&C	
2	1	DH0286	3 PORT 3000 PSI MODULATING VALVE	
3	2	HH0750	90° ADJUSTABLE MALE ORB TO JIC, 853-8-8	
4	3	HH0738	90° ADJUSTABLE MALE ORB TO JIC, 853-4-4	
5	1	HH0657	MALE ORB TO JIC ADAPTER, 850-4-4	
6	1	HH0807	90° ADJUSTABLE FEMALE JIC TO MALE JIC, 863-4-4	
7	8	XH0001	7MM EXPANSION PLUG, MB850-07-07	
8	1	VHH041	CARTRIDGE VALVE, HydraForce CV08-20-0-N-25	
9	1	VHH049	CARTRIDGE VALVE, HydraForce CV08-20-0-N-150	
10	1	DH0159	SUN FCCB-LAN WITH .040" ORFICE	
11	1	DH0158	SUN FCCB-LAN WITH .088" ORFICE	
12	1	VHSF19	CARTRIDGE VALVE, SUN FXEA-LIN	
13	1	VHSO08	Series 3 - 15.6 GPM (.242") Orifice	
14	1	FRD050	.500 ø SHAFT, INTERNAL LOCK RING	

DH0152 BAR OIL TANK ASSEMBLY

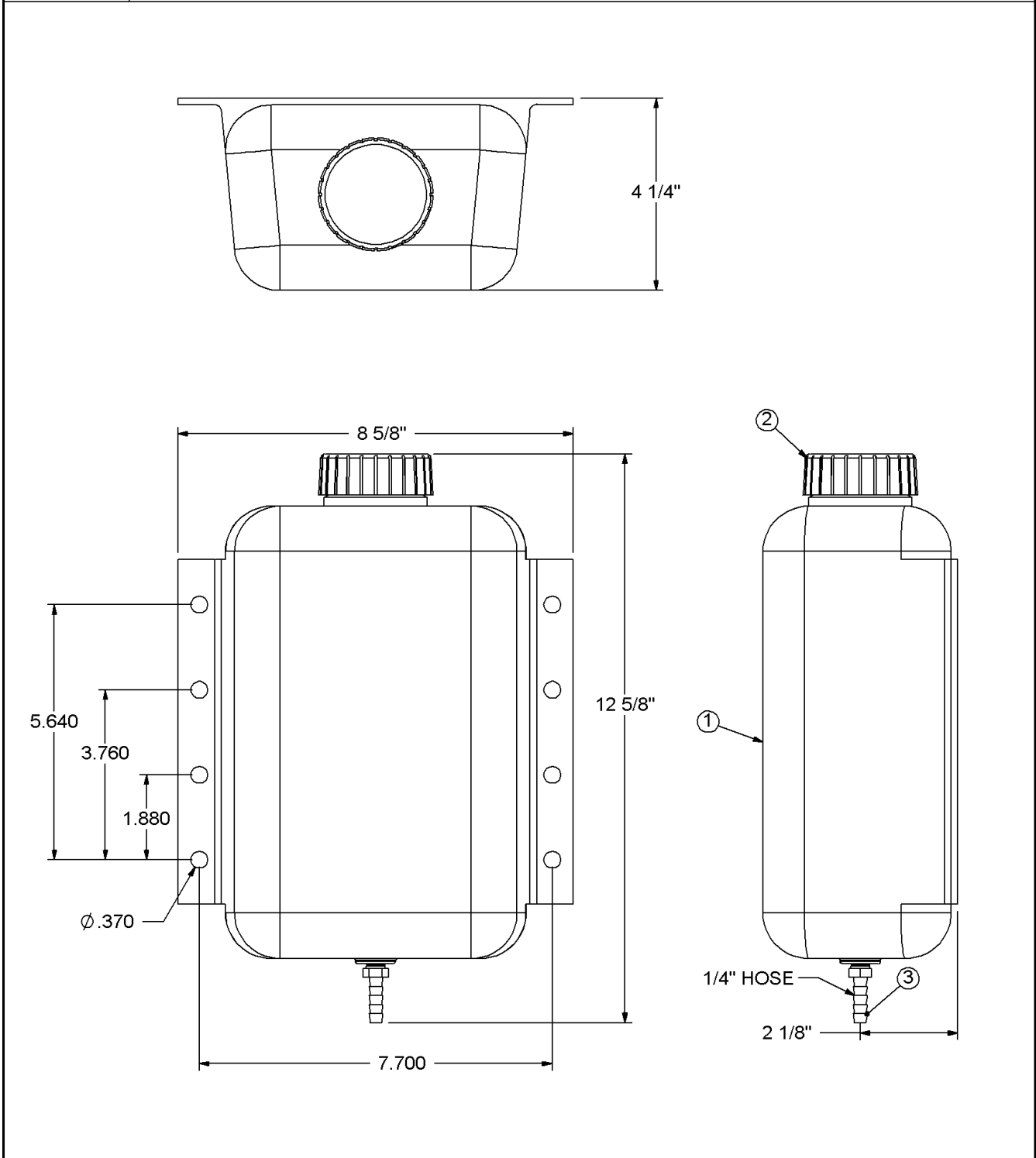

ITEM No.	QTY.	PART No.	DESCRIPTION	REMARKS
1	1	DH0150	BAR OIL TANK, 4 Quart	
2	1	DH0151	BAR OIL TANK CAP	
3	1	HB0007	HOSE END, 1/8 PIPE X 1/4 HOSE	

HOSE LAYOUT

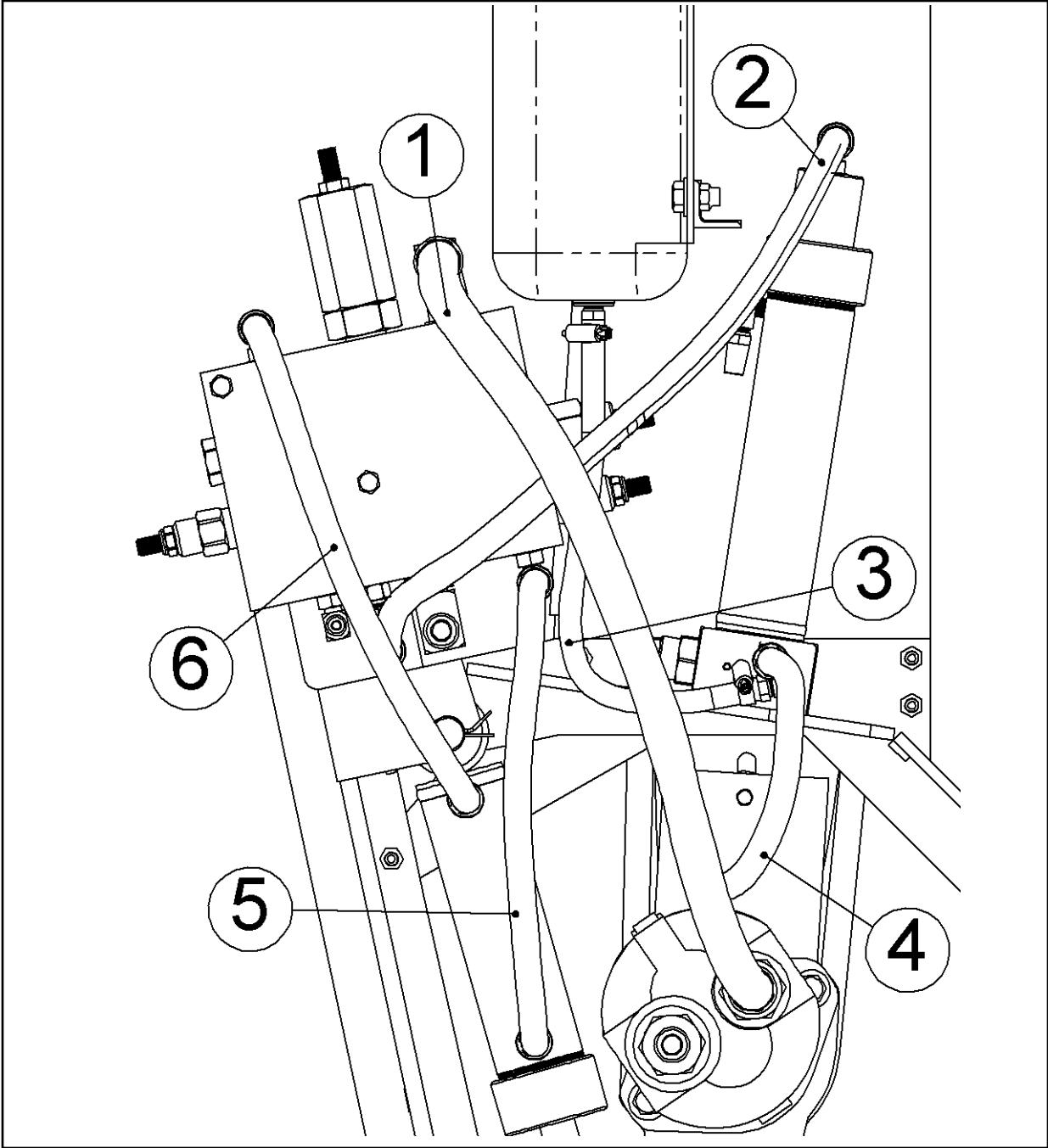

ITEM No.	QTY.	PART No.	DESCRIPTION	REMARKS
1	1	DH0199	SAW MOTOR HOSE, 38" OAL	#8 - 3000 PSI HOSE
2	1	DH0200	MANIFOLD TO BAR OIL PUMP HOSE, 24.5" OAL	#4 - 3000 PSI HOSE
3	1	DH0180	OIL TANK TO BAR OIL PUMP HOSE, 12" OAL	4LOLB
4	1	DH0181	BAR OIL PUMP TO BAR PLATE HOSE, 24.5" OAL	#4 - 3000 PSI HOSE
5	1	DH0197	CUT HOSE, 20.5" OAL	#4 - 3000 PSI HOSE
6	1	DH0198	RETRACT HOSE, 20.5" OAL	#4 - 3000 PSI HOSE